

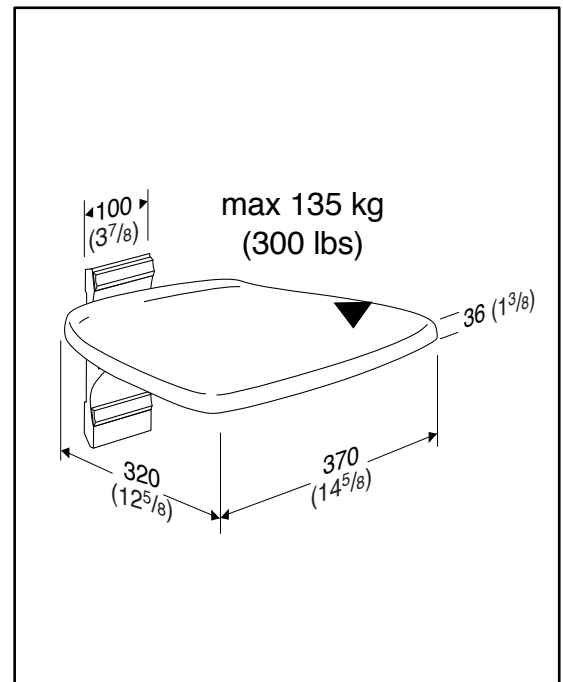

Ret til ændringer forbeholdes. Recht auf Änderungen sind vorbehalten. Subject to alteration without further notice. Nous nous réservons le droit d'apporter toutes modifications pour l'amélioration de nos produits sans préavis. Wijzigingen voorbehouden. Salvo variaciones. Salvo variazioni. Rätten till ändringar förbehålles. Vi förbehåller oss rätt till ändringar. Kaikki oikeudet muutoksiin pidätetään. Rettur til breytinga áskilinn. Reservado o direito de fazer modificações sem prévio. Επιφυλασσομέθεα για εκτυπωτικά γάθη, μικρές τεχνικές αλλαγές και παρεκκλίσεις μοντέλων.

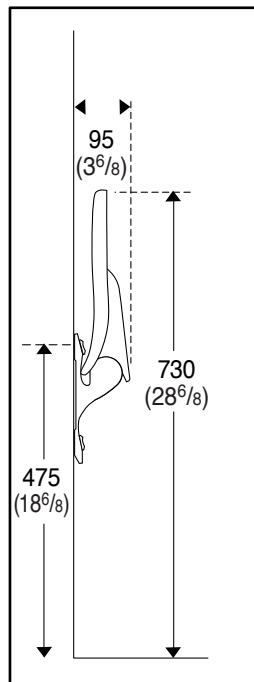
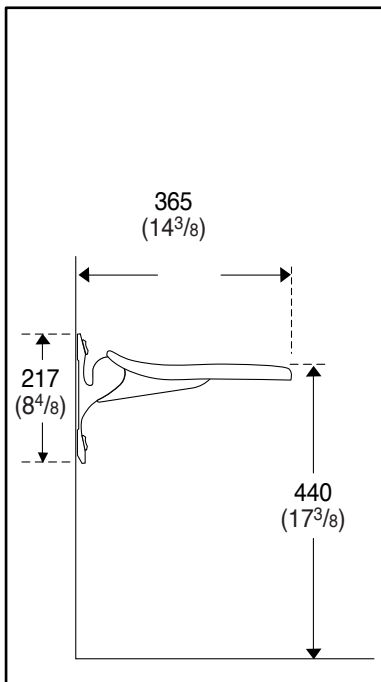
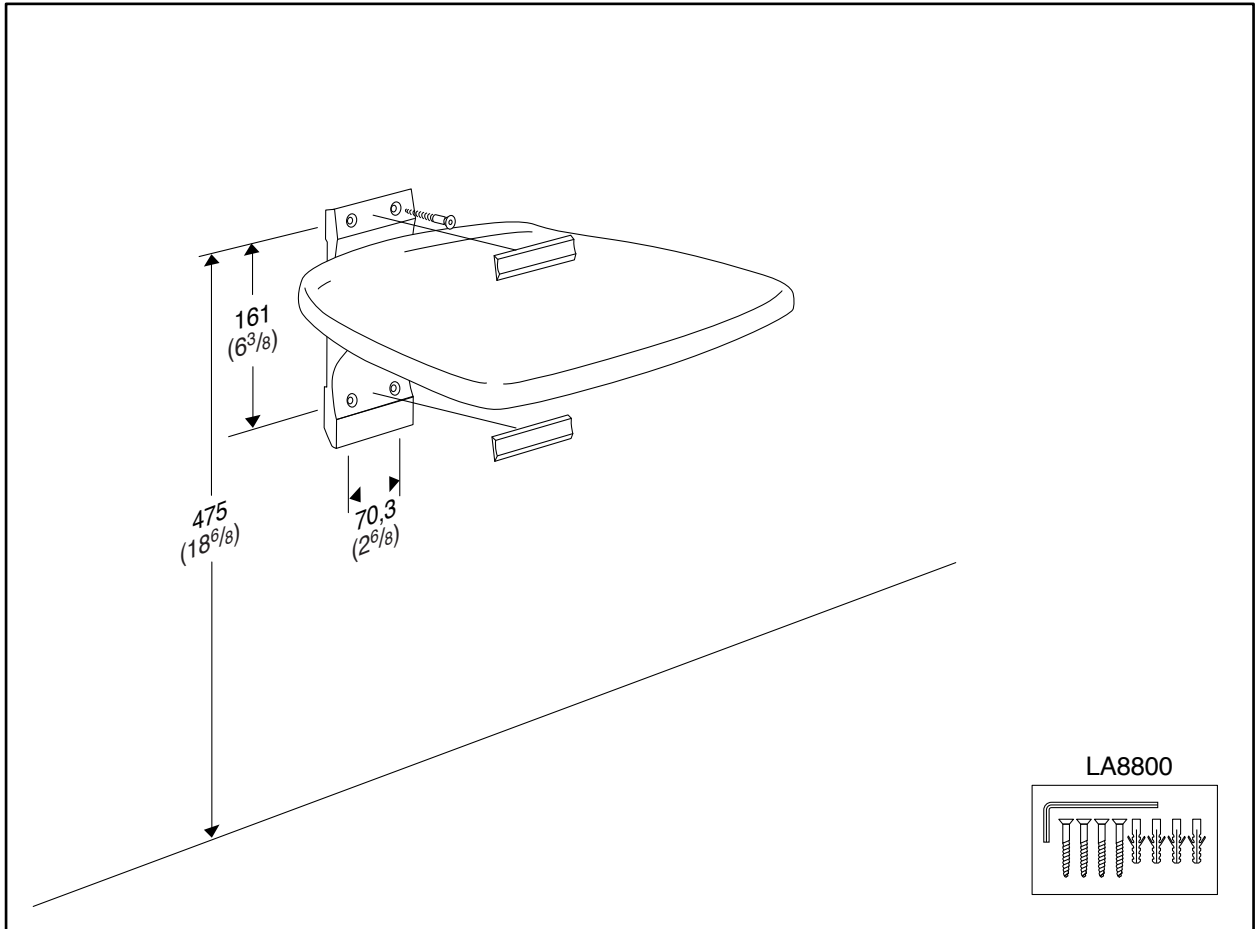

keep living

Telephone: +45 87 888 777  
 Telefax: +45 87 888 669  
 E-mail: mail@pressalitcare.com  
 Web: www.pressalitcare.com

Pressalit Care  
 Pressalitvej 1  
 DK 8680 Ry  
 Denmark

## 08/05/Mounting Info

DK	Murstensvægge (massiv mursten eller hulsten) >Mz12 eller >Hlz12	2"x1,5" lægte, 22 mm krydsfiner eller lign.	2x12,5 mm gipsplader eller lign.	Gasbetonvægge > G2	Betonvægge > B15
D	Bäcksteinwände (Vollstein oder Lochsteinen) >Mz12 oder >Hlz12	2"x1,5" Latten, 22 mm Sperrholz oder desgl.	2x12,5 mm Gipsplatten oder desgl.	Gasbetonwände > G2	Betonwände > B15
GB	Brick walls (solid brick or hollow brick) >Mz12 or >Hlz12	2"x1,5" studs, 22 mm (7/8") plywood or equivalent	2x12,5 mm (4/8") plasterboard or equivalent	Aerated concrete walls > G2	Concrete walls > B15
F	Murs de brique (brique pleine ou brique alvéolaire) >Mz12 ou >Hlz12	2"x1,5" lattes, 22 mm contre-plaqué ou similaire	2x12,5 mm plaque de plâtre ou similaire	Murs de béton cellulaire > G2	Murs de béton > B15
NL	Gemetselde wanden (bakstenen of holle stenen) > Mz12 of > Hlz12	2"x1,5" rachel, 22 mm multiplex o.i.d.	2x12,5 mm gipsplaten	Gasbetonwanden > G2	Betonwanden > B15
E	Paredes de ladrillo (ladrillo macizo o ladrillo hueco) >Mz12 o >Hlz12	Puntales de 2"x1,5", madera contrachapada de 22 mm o similar	2x12,5 mm recubrimi- entos de placas de fibra yeso, yeso-carlón, o similar	Paredes de hormigón poroso > G2	Paredes de hormigón > B15
I	Muri in mattoni (mattoni pieni o forati) >Mz12 o >Hlz12	2"x1,5" assicelle, 22 mm legno compensato o similari	2x12,5 mm lastre di gesso o similari	Muri in calcestruzzo areato > G2	Muri in calcestruzzo > B15
S	Tegelväggar (massiv tegel eller med håll) > Mz12 eller > Hlz12	2" x 1,5" läkt, 22 mm plywood eller motsvarande	2 x 12,5 mm gipsskiva eller liknande	Väggar av lättbetong > G2	Betongväggar > B15
N	Mursteinsvegger (massiv murstein eller hulstein) > Mz12 eller > Hlz12	2" x 1,5" lekter, 22 mm kryssfiner eller lign.	2 x 12,5 mm gipsplater eller lign.	Gassbetongvegger > G2	Betongvegger > B15
FIN	Tiiliseinä (massiivinen tai ontto tiili) > Mz12 tai > Hlz12	2" x 1,5" tukipuu, 22 mm:n ristivaneri tmv.	2 x 12,5 mm:n kipsilevy tmv.	Kevytbetoniseinät > G2	Betoniseinät > B15
IS	Múrsteinsveggir (gegnheill múrsteinn eða holsteinn) >Mz12 eða >Hlz12	2"x1,5" listi 22 mm krossviður eða p.h.	2x12,5 mm gífsplötur eða p.h.	Léttsteypuveggur > G2	Steinsteypuveggur > B15
P	Paredes de tijolo (tijolo maciço ou furado) > Mz12 ou > Hlz12	Prumos de 2" x 1,5" mm, contraplacado de 22 mm ou equivalente	Placas de gesso de 2 x 12,5 mm ou equivalente	Paredes de betão celular > G2	Paredes de betão > B15
GR	Τοίχος από τούβλα (ομαπή ή μη) > Mz12 ή > Hlz12	2" X 1,5" κοχλίας 22 mm κόντρα πλακέ ή κάτι παρόμοιο	2 X 12,5 mm γυψοσανίδα ή κάτι παρόμοιο	Τοίχος, μπετόν πορώδες >G2	Τοίχος από μπετόν > B15
R9900-R9915	B	B	C	C	C
R3016/R3018	A ✓	A ✓	X	E	A ✓ □
RF016/RF018	A ✓	A ✓	X	E	A ✓
R3146/R3148	B	B	C □	F	B □
RF146/RF148	B	B	C □	F	B □
R4140/R4141/42	B	B	C	F	B
R4260/R4270/R4261/62/71/72	B ✓ □	B ✓	C	F	B ✓ □
R4360/R4361/62/71/72	B ✓	B ✓	C	F	B ✓
R5010/R5015/R7010	A ✓	A ✓	X	E	A ✓ □
R5140/R5145	B	B	C □	F	B □
R6010	B ✓	B ✓	C □	F □	B ✓ □
R7165/66/67/68	B	B	C □	F	B □
R7142/R7143/R7150/R7151	B	B	C	F	B
R7256/R7258	B	B	C	F	B
R4920/21/R4930/31	B ✓	B ✓	C	F	B ✓
R8240/41-61/R8245/46-66	B ✓	B ✓	C	F □	B ✓ □
RT490/RT491/RT850-870	D ✓	D ✓	X	D ✓	D ✓ □
RT100-110/RT124-138	D ✓	D ✓	X	D ✓	D ✓ □
RT114-119/RT212-215	D ✓	D ✓	X	D ✓	D ✓

- ✓ Medsendes produktet • Liegt dem Produkt bei • Included with the product • Fournie avec le produit  
 Wordt met het product mee gezonden • Includido con el producto • Allegato al prodotto • Produkten skickas med • Følger med produktet  
 Lähetetään tuotteen mukana • Fylgi vörinni • Envía-se anexo ao produto • Συνοδεύει το προϊόν
- X Ikke muligt • Nicht möglich • Not possible • Impossible • Niet mogelijk • Imposible • Impossibile • Ej möjligt • Ikke mulig • Ei mahdollinen  
 Ekki mögulegt • Não possível • Αδύνατον

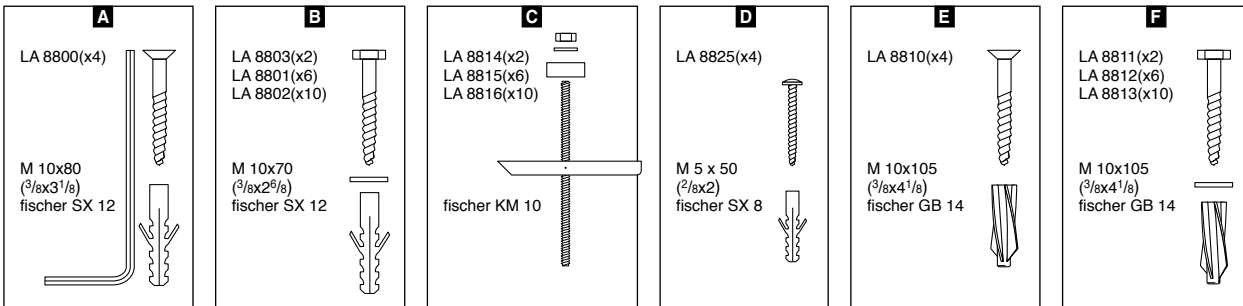

Kun vejledende • Nur richtungsweisend • Guidelines only • Le guide n'a qu'une valeur indicative • Niet te beoordelen  
 Solamente a título indicativo • Solamente a título indicativo • Endast anvisning • Kun vejledende • Vain ohjeellinen  
 Aðeins til leiðbeinandi • Apenas linhas de orientação • Μόνο βοηθητικές γραμμές.



keep living

Telephone: +45 87 888 777  
 Telefax: +45 87 888 669  
 E-mail: mail@pressalitcare.com  
 Web: www.pressalitcare.com

Pressalit Care  
 Pressalitvej 1  
 DK 8680 Ry  
 Denmark

Ret til ændringer forbeholdes. Recht auf Änderungen sind vorbehalten. Subject to alteration without further notice.  
 Nous nous réservons le droit d'apporter toutes modifications pour l'amélioration de nos produits sans préavis.  
 Wijzigingen voorbehouden. Salvo variaciones. Rätten till ändringar förbehålles. Vi förbehåller oss rätt till ändringar.  
 Kaikki oikeudet muutoksiin pidätetään. Rettur til breytinga áskilinn. Reservado o direito de fazer modificações sem prévio  
 Επιφυλασσομένα για εκτινπωτικά γάθη, μικές τεχνικές αλλαγές και παρεκκλίσεις μοντέλων.